

# TOPAS

---

## Traffic Open Products and Specifications

### ***TOPAS 2543A***

### ***Performance Specification for Signal Heads***

<b>Revision</b>	<b>Date</b>	<b>Scope</b>	<b>Authorised by</b>
A	14/02/24	Issue	

© Traffic Open Products and Specifications Limited 2024.

This document is the property of Traffic Open Products and Specifications Limited and shall not be reproduced in any media in part or in full without the prior written permission of Traffic Open Products and Specifications Limited unless this copyright statement is attached.

Contains public sector information licensed under the Open Government Licence v3.0 and are reproduced and adapted by permission.

#### **Limitation of Liability**

Traffic Open Products and Specifications Limited does not accept any liability for any losses damages injury or death or other adverse consequence arising from the use or application of this document and the information therein

*[This page has been left intentionally blank*

## **TOPAS 2543A**

### **PERFORMANCE SPECIFICATION FOR SIGNAL HEADS**

## **CHANGE LOG**

Specification first issue so there are no change log entries.

## **CONTENTS**

### **Section**

- 1 Introduction
- 2 Functional Requirements
- 3 References

**Appendix A:** Other Information

**Appendix Z:** Technical File Content

## 1 INTRODUCTION

1.1 This performance specification covers the necessary requirements for traffic signalling equipment used in conjunction with traffic control systems.

**Note.** Throughout this specification the term 'pedestrian' refers to all types of non-motorised vehicle users, including cyclists and equestrians.

1.2 TOPAS specifications are explicitly purchasing specifications and compliance with them is not mandatory. However Local and other Purchasing Authorities may typically require that equipment purchased complies with TOPAS specifications and is TOPAS registered.

1.3 Manufacturers may register products as being compliant with this specification, using the process defined in TOPAS 0600.

1.4 TOPAS registration requires manufacturers submit a Technical File to an appropriate Technical Assessor to aid compliance verification. The content requirement for the Technical File is defined in Appendix Z of this specification.

1.5 Within this specification, "The Product" shall mean all components necessary to provide a complete operational unit meeting the requirements of this specification and the common requirements defined in TOPAS 0600.

1.6 This Specification includes requirements for the signals used in equipment for portable and permanent traffic signalling systems. Performance requirements for all other characteristics of portable traffic signalling systems are defined in TOPAS 2540. Only if a facility or requirement is NOT provided in TOPAS 2540 shall the requirements of this specification apply.

### *Implementation*

1.7 This specification will be immediately implemented from the date of issue for all new TOPAS Registrations.

### *Glossary of Terms and Abbreviations*

A comprehensive glossary of terms and abbreviations may be found in the Institute of Highway Engineers guidance note "Traffic Control and Information Systems". TOPAS Terms are defined in TOPAS 0600 and TOPAS 0601.

## 2 FUNCTIONAL REQUIREMENTS

### *General*

2.1 The Products defined in this specification are used to provide information and instructions to road users by means of light signals and or illuminated signs.

2.2 In the event of any ambiguity or interpretation the requirements of TSRGD and the references to BSEN 12368 within it take precedence over this specification.

2.3 This specification provides functional definitions for

- All variants of 200mm traffic signals including far-side pedestrian signals and light signals at level crossings, swing or lifting bridges, airfields and premises used by emergency vehicles,
- 100mm cycle signals,
- regulatory signs used within a traffic signal assembly,
- secret regulatory signs used within a traffic signal assembly.

2.4 The signals defined in this specification may support any of the masks or legends prescribed in TSRGD or specially authorised by the Secretary of State.

2.4.1 Backing boards are not required for 100mm cycle signals.

2.4.2 Wigwag signals shall have the backing board size and border shown in TSRGD diagram 3014.

2.4.3 For all other signals either,

- i. the container shall be black with a minimum of 25 mm around each signal aspect, or

- ii. Where backing boards are used they may have a white border between 45 and 55mm wide

2.5 This Specification collates those parts of BS 505, TR 1020, TR 2206 and other specifications that have not been assimilated into BS EN 12368, TSRGD:2016 or into other locations for the purposes of ensuring definition of functionality.

### *Reliability*

2.6 The Product shall have a design life of at least 10 years with suitable maintenance.

## Documentation

2.7 Full installation, commissioning and maintenance instructions shall be published for the Product. These shall be identifiable by part number and issue state.

## Labelling

2.8 In addition to mandatory markings, (such as UKCA or equivalent), the Product shall also be clearly marked with:

- a) Its Product designation (such as the Manufacturer's part number) and a unique serial number.
- b) Its power supply requirements; whether LV or ELV, the operating voltage range(s) and corresponding power or current consumption. Permitted voltage ranges are defined in TOPAS 2523.
- c) Where the Product emits any form of coherent light (for example low power laser light) it shall include the prescribed Laser Product label.
- d) For 200mm signals, those requirements of BSEN 12368 that are met by the product. (For details see table 1 and TSRGD.)

## Traffic Signals

### 200mm Diameter Traffic Signals

2.9 For the purposes of this specification a 200mm traffic signal means all of the equipment, signal aspects, housings, visors, bracket adaptors, and brackets that are needed to mount a traffic signal assembly to a pole or other recognised and permitted structure. The term "200mm traffic signals" includes pedestrian far side signals comprising of a mask placed over a 200mm traffic signal and wig-wag signals.

### Optical Performance

2.10 The optical performance criteria for 200mm traffic signals and masked 200mm traffic signals are reproduced from TSRGD and are tabulated below for convenience.

Table 1

<i>(1) Item</i>	<i>(2) Aspect of performance</i>	<i>(3) Requirement or test specification and class</i>
1	Protection rating	Class IV: IP 55
2	Operating temperature range	Class A
3	Luminous intensity	Performance level 3, class 2
4	Distribution of luminous intensity	Type M
5	Maximum signal phantom	Class 5
6	Signal lights incorporating symbols	Class S1
7	Background screen	The requirement in the BS EN 12368 Note 1
8	Impact resistance	Class IR2

Note 1. Where the Background screen is stated as being 'opaque' it must also be black or, where so defined in TSRGD, grey. Where the opaque rim shall be a minimum of 25mm, additionally it shall be increased to a minimum horizontal width of 350mm for Diagram 3000 signals.

2.11 In the dimmed state the luminous intensity shall be reduced as defined in TOPAS 2523 and CLC/TS 50509.

### ***Electrical Performance***

2.12 200mm traffic signals for portable traffic signal systems shall have the electrical performance defined in TOPAS 2523

2.13 200mm traffic signals for permanent traffic signal systems shall operate from either LV or ELV supplies.

2.14 The ranges of operating voltages for LV and ELV operation of the Product in bright and dim modes are specified in the Power Supplies section of TOPAS 2523.

2.14.1 The means of applying the supply voltage for the signal may be either centralised from the controller or distributed as defined in BS EN 50556

2.14.2 Except for portable signals the means of controlling the bright / dim state for the signal shall be centralised from the controller or distributed as defined in BS EN 50556

2.15 In either case, LV or ELV the signal shall be off for any voltage below the lowest dim voltage. For voltages between the minimum bright and maximum dim state the signal may be in either the bright only or the dim state only but not at any level in between these.

2.16 Voltage hysteresis shall be provided for changes between all signal states.

2.17 Interoperability: It is not the intention of this performance specification to guarantee interoperability of 200 mm permanent traffic signal and permanent traffic signal controllers between different suppliers, and reference should be made to manufacturer's guidelines when considering combinations of signals and controllers.

2.17.1 The signal aspects shall offer a power factor that meets the requirements of Elexon.

2.17.2 The total harmonic distortion shall meet the requirements of Elexon for both bright and dim operation.

2.18 Earthing: Where enclosures or any other accessible parts of the signal are conductive they shall be bonded to earth as required by BS EN 50556.

### ***Construction and Mechanical Performance***

2.19 Dimensions, spacings and mounting heights for traffic signals are provided in TSRGD. There are different values for portable and permanent traffic signals.

2.20 For the purposes of compliance with this specification the Product shall include components such as anti-rotation end caps, fixings and brackets, all of which shall be specifically identified in the Product Technical File.

2.21 All exposed parts of the Product shall be constructed from materials that are designed to be stable to ultraviolet light exposure in their service environment. Information shall be included in the technical file to substantiate the choice of materials and coatings.

2.22 200mm traffic signals shall continue to conform to the requirements of this specification when subjected to the environmental conditions of BS EN 50556 and BS EN 12368

2.23 Signal heads shall be capable of accepting and making a robust connection to those sizes of conduit used for the protection of their electrical wiring.

2.24 Mounting brackets shall be black unless other colours are requested in the works order.

2.25 Mounting brackets shall be designed to allow the use of the standard high tensile steel M8 U bolts for attachment of the signal head bracket to the pole or other structure including 6m or 8m poles, mast-arms or gantries.

2.26 Mounting brackets and anti-rotation facilities shall support the load of the signal and prevent detachment or permanent rotation of the signal head under loading conditions of wind speeds of 145 km/hr.

2.27 Manufacturers may demonstrate compliance with this requirement through providing evidence of at least one of

2.27.1 Wind tunnel testing

2.27.2 Desktop calculation

2.27.3 For pre-existing Products Records of maintenance intervention on an installed number of at least 200 signal heads that have been in operation for at least 2 years.

2.28 Visors shall conform to the drawings of Appendix A

2.29 When mounted to signal heads, visors shall withstand a wind load of 145km/hr without becoming detached or undergoing permanent deformation. This may be demonstrated in the Product Technical File by evidence for the secondary visor type of one or more of

2.29.1 Wind tunnel testing

2.29.2 Desktop calculation

2.29.3 For pre-existing Products, records of maintenance intervention on an installed number of at least 200 signal heads supporting secondary visors that have been in operation for at least 2 years.

### ***EMC and Environmental requirements***

2.30 The environmental performance requirements for 200mm traffic signals are provided in the appropriate parts of TOPAS 2130

2.31 200 mm traffic signals shall conform to the requirements of BS EN 50293. This shall be evidenced in the Technical File

### ***100mm Diameter Cycle Signals***

2.32 For the purposes of this specification a 100mm traffic signal is all that equipment, signal aspects, housings, visors, bracket adaptors, and brackets that are needed to mount a traffic signal assembly to a pole or other recognised and permitted structure.

### ***Optical Performance***

2.33 The optical performance criteria for 100 mm cycle signals and masked 100 mm traffic signals are reproduced from TSRGD and are tabulated below for convenience.



(1) Item	(2) Aspect of performance	(3) Requirement or test specification and class
1	Protection rating	Class IV: IP 55
2	Operating temperature range	Class A
3	Luminous intensity	Performance level 1, class 1
4	Distribution of luminous intensity	Type W
5	Maximum signal phantom	Class 1
6	Signal lights incorporating symbols	Class S1
7	Impact resistance	Class IR2 or IR3

2.34 In the dimmed state the luminous intensity shall be reduced as defined in TOPAS 2523.

### **Electrical Performance**

2.35 100 mm traffic signals for permanent traffic signal systems shall operate only from ELV supplies.

2.36 The ranges of operating voltages for ELV operation of the Product in bright and dim modes are specified in the Power Supplier section of TOPAS 2523.

2.36.1 The means of applying the supply voltage for the signal may be either centralised from the controller or distributed as defined in BS EN 50556

2.36.2 Except for portable signals the means of controlling the bright / dim state for the signal shall be centralised from the controller or distributed as defined in BS EN 50556

2.37 The signal shall be off for any voltage below the lowest dim voltage and above the highest bright voltage. For voltages between the minimum bright and maximum dim state the signal may be in either the bright only or the dim state only but not at any level in between these.

2.38 Voltage hysteresis shall be provided between the bright to dim and dim to bright transitions.

2.39 Interoperability: It is not the intention of this performance specification to guarantee interoperability of 100 mm permanent cycle signal and permanent traffic signal controllers between different suppliers, and reference should be made to manufacturer's guidelines when considering combinations of signals and controllers.

2.39.1 The signal aspects shall offer a power factor that meets the requirements of Elexon.

2.39.2 The total harmonic distortion shall meet the requirements of Elexon for both bright and dim operation.

2.40 Earthing: Where enclosures or any other accessible parts of the signal are conductive they shall be bonded to earth as required by BS EN 50556.

### **Construction and Mechanical Performance**

2.41 Dimensions, spacings and mounting heights for traffic signals are provided in TSRGD.

2.42 For the purposes of compliance with this specification the Product shall include anti-rotation end caps or other means to prevent mischievous misalignment, fixings and brackets, all of which shall be specifically identified in the Product Technical File.

2.43 All exposed parts of the Product shall be constructed from materials that are designed to be stable to ambient ultraviolet light exposure in their service environment. Information shall be included in the technical file to substantiate the choice of materials and coatings.

2.44 When subjected to the environmental conditions of TOPAS 2130 no part of the Product shall not undergo any deformation or distortion that breach any criteria of this specification.

2.45 100 mm cycle signal heads shall provide means for the protection of their external electrical wiring.

2.46 Mounting brackets, end caps and all other external parts of the signal body shall be black.

2.47 Mountings fixings, fastenings and closures shall be designed to prevent tampering or access to the signal enclosure without the use of special tools.

2.48 Separate visors are not required for 100 mm cycle signals.

### ***EMC and Environmental requirements***

2.49 The environmental performance requirements for 100 mm cycle signals are provided in the appropriate parts of TOPAS 2130

2.50 100 mm cycle signals shall conform to the requirements of BS EN 50293. This shall be evidenced in the Technical File

### ***Regulatory Signs***

#### ***Optical Performance***

2.51 For the purposes of this specification Regulatory Signs either one of the following

2.51.1 A regulatory sign prescribed in TSRGD or specially authorised by the Secretary of State that may be placed in a traffic signal head housing located according to the diagrams of Schedule 14 part 3 of TSRGD and which are internally illuminated. Such signs have a nominal diameter of 300mm.

2.51.2 A regulatory sign prescribed in TSRGD or specially authorised by the Secretary of State that may be placed in a cycle signal head housing located according to the diagrams of Schedule 14 part 3 of TSRGD and which are internally illuminated. Such signs have a nominal diameter of 100mm.

2.52 Suggested mounting arrangements for common scenarios are available in Chapter 6 of the Traffic Signs Manual.

2.53 The light source used to illuminate Regulatory signs shall be white as defined in BS EN 12899-1. The transilluminated the sign face shall meet the UK requirements of BS EN 12899-1.

2.54 The internal illumination for a regulatory sign may be in the 'off' state for those applied voltages corresponding to the off state of traffic signals.

### ***Electrical Performance***

2.55 The light source for the transillumination of the regulatory sign legend may be powered by a separate supply from the traffic signal controller from that used to power the traffic signal aspects.

2.56 The ranges of operating voltages for 300mm diameter signs are those LV and ELV supplies that are specified in the Regulatory Signs sub-section of the Power Supplies section of TOPAS 2523.

- 2.56.1 The means of applying the supply voltage for the signal may be either centralised from the controller or distributed as defined in BS EN 50556

2.57 The ranges of operating voltages for 100mm diameter signs are those ELV supplies that are specified in the Regulatory Signs sub-section of the Power Supplies section of TOPAS 2523.

- 2.57.1 The means of applying the supply voltage for the signal may be either centralised from the controller or distributed as defined in BS EN 50556

2.58 Regulatory signs are not dimmed.

2.59 Interoperability: It is not the intention of this performance specification to guarantee interoperability of regulatory signs and permanent traffic signal controllers between different suppliers, and reference should be made to manufacturer's guidelines when considering combinations of signals and controllers.

- 2.59.1 The signal aspects shall offer a power factor that meets the requirements of Elexon.

- 2.59.2 The total harmonic distortion shall meet the requirements of Elexon for both bright and dim operation.

2.60 Earthing: Where enclosures or any other accessible parts of the signal are conductive they shall be bonded to earth as required by BS EN 50556.

### ***Construction and Mechanical Performance***

2.61 The Regulatory Sign face shall be incorporated into a traffic signal head housing and shall meet the requirements of sections 2.19 to 2.29 above.

### ***EMC and Environmental requirements***

2.62 The environmental performance requirements for illuminated regulatory signs are provided in the appropriate parts of TOPAS 2130

2.63 Regulatory signs shall conform to the requirements of BS EN 50293. This shall be evidenced in the Technical File

### ***Secret Regulatory Signs***

#### ***Optical Performance***

2.64 For the purposes of this specification Regulatory Signs means regulatory signs prescribed in TSRGD or specially authorised by the Secretary of State that may be placed in a signal head housing located according to the diagrams of Schedule 14 part 3 of TSRGD and which are internally illuminated and which signs are permitted to be used in a part time operational mode (so called secret signs). Such signs have a nominal diameter of 300mm.

2.65 Suggested mounting arrangements for common scenarios are available in Chapter 6 of the Traffic Signs Manual.

2.66 The light source used to illuminate Secret Regulatory signs shall be white as defined in BS EN 12899-1. The transilluminated the sign face shall meet the UK requirements of BS EN 12899-1.

2.67 In their obscured or secret state the sign face shall meet all of the following criteria.

- 2.67.1 Measurement shall be performed on a secret sign that displays diagram 614 of TSRGD (no U turn)

- 2.67.2 Test Conditions: Testing shall be performed under the standard external phantom illumination conditions of BSEN12368. The secret regulatory sign internal illumination shall be turned off.
- 2.67.3 Nine 25 mm diameter circular sampling areas shall be identified by the test body. Of the nine measurements four shall coincide with the red outer ring of the sign, three shall coincide with the black region of the symbol and two shall coincide with the white part of the sign. Measurement areas shall be distributed across the sign face and no areas shall overlap each other.
- 2.67.4 Measurements of luminance and chromaticity shall be made at all the defined sampling areas.
- 2.67.5 The ratio of the highest luminance to the lowest luminance shall not exceed 1.2
- 2.67.6 All chromaticity measurement shall fall within a square box on the CIE 1931 chromaticity diagram of no greater extent than 0.05 units in both the x and y directions and this box shall also enclose the chromaticity point 0.333, 0.333.

## **Electrical Performance**

- 2.68 The light source for the transillumination of the secret regulatory sign legend shall be powered by a separate supply from the traffic signal controller from that used to power the traffic signal aspects.
- 2.69 The ranges of operating voltages for 300mm diameter secret signs are those LV and ELV supplies that are specified in the Regulatory Signs sub-section of the Power Supplies section of TOPAS 2523.
- 2.69.1 The means of applying the supply voltage for the signal may be either centralised from the controller or distributed as defined in BS EN 50556
- 2.70 The internal illumination for a secret regulatory sign shall be in the 'off' state for those applied voltages corresponding to the off state of traffic signals.
- 2.70.1 For secret regulatory signs where the element conveying secrecy is powered, it shall take the secret state for those voltages corresponding to the off state of traffic signals.
- 2.71 Secret regulatory signs are not dimmed.
- 2.72 Interoperability: It is not the intention of this performance specification to guarantee interoperability of secret regulatory signs and permanent traffic signal controllers between different suppliers, and reference should be made to manufacturer's guidelines when considering combinations of signals and controllers.
- 2.72.1 The signal aspects shall offer a power factor that meets the requirements of Elexon.
- 2.72.2 The total harmonic distortion shall meet the requirements of Elexon for both bright and dim operation.

2.73 Earthing: Where enclosures or any other accessible parts of the signal are conductive they shall be bonded to earth as required by BS EN 50556.

### ***Construction and Mechanical Performance***

2.74 The Secret Regulatory Sign face shall be incorporated into a traffic signal head housing and shall meet the requirements of sections 2.19 to 2.27 above.

### ***EMC and Environmental requirements***

2.75 The environmental performance requirements for illuminated regulatory signs are provided in the appropriate parts of TOPAS 2130

2.76 Regulatory signs shall conform to the requirements of BS EN 50293. This shall be evidenced in the Technical File

## 3 REFERENCES

3.1 Where undated references and standards are listed, the latest issue of the publication applies.

### **British Standards**

3.2 The British Standards Institution, London, publishes British Standards.

BS EN 50556	Road Traffic Signal Systems
BS EN 50293	Electromagnetic Compatibility Road Traffic Signal Systems Product Standard
BS EN 12675	Traffic Signal Controllers – functional safety requirements
BS EN 12899 1	Fixed, vertical road traffic signs. Part 1: Fixed signs
CLC/TS 50509	Use of LED Signal Heads in Road Traffic Signal Systems

### **Specifications**

3.3 TOPAS Limited specifications are available at [www.topasgroup.org.uk](http://www.topasgroup.org.uk)

TOPAS 0600	TOPAS Registration Process
TOPAS 2523	Traffic Control Equipment Interfacing Specification
TOPAS 2130	Environmental Tests for Road Traffic Control Equipment

### **Other Publications**

3.4 Other publications can be obtained from various sources including the Stationary Office:

TSRGD	Traffic Signs Regulations and General Directions
CIE Colour Coordinates	CIE 15:2004, Colorimetry
IEC 60825-1	Safety of laser products - Part 1: Equipment classification and requirements

## APPENDIX A – OTHER INFORMATION

Visor/hood drawings

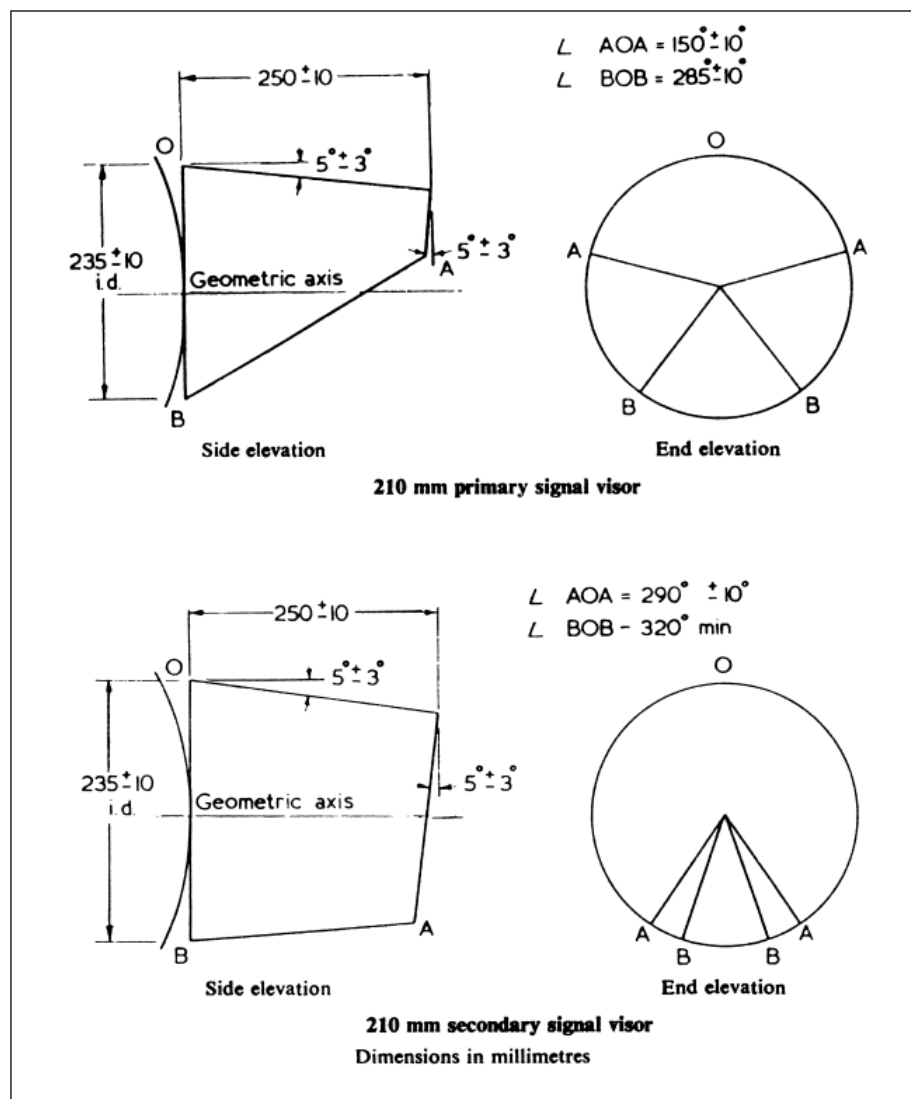

Figure 1 200mm Signal Visor Drawings

## APPENDIX Z TECHNICAL FILE CONTENT

This appendix defines the necessary content for a Technical File (a collection of relevant documents) which must be reviewed by an appropriate Technical Assessor as part of the TOPAS Registration process (See TOPAS 0600).

The 'ticked' items are required to be present in a Technical File used to support TOPAS Registration against TOPAS 2543A. **Please read the description criteria carefully.**

<i>Ref</i>	<i>Item</i>	<i>Description</i>	<i>Required</i>
1	Overview document	A summary document outlining the product, specifying which TOPAS and other relevant specification(s) the product has been designed to comply with, together with a detailed table of contents for the Technical File.  Where external certificates or documents are referred to these shall be included either:  (a) within this overview document; or  (a) (b) supplied separately as part of this Technical File.	✓
2	QA accreditation certificate(s)	A copy of the Quality Management Registration Certificates for the organisation applying for TOPAS Product Registration.	✓
3	Details of all required standards and regulations including CE/CA requirements that apply to the Product	A list of all standards to be complied with.  Including explicit CE/CA declarations of performance/conformity for those standards, including all certificates, shall be included in this Technical File.	✓
4	A functional design description of the product	Title, document number, version and date of the overall System Design Document for the Product.	✓
5	Product part numbers	A list of top-level assembly part numbers and their issue states including all firmware / software part numbers and issues.	✓
6	Statement of Compliance	A clause-by-clause statement of compliance against TOPAS 2543A confirming compliance or non-compliance and referencing supporting evidence.  (An example template can be found on the TOPAS website)	✓



7	Functional test procedures and results	A list of all functional test schedules and test result documents (by document number and issue) that substantiate the Statement of Compliance.	✓
8	BS EN 50293 EMC test procedures and results	<p>(a) Title, document number, version and date of the EMC test performance requirement document.</p> <p>(a) Copies of the results of EMC testing undertaken by an appropriately qualified independent approved test house <u>must</u> be included in the Technical File.</p>	✓
9	Optical test procedures and results required by this specification	<p>For all products which have any defined optical performance requirements</p> <p>(a) Title, document number, version and date of the optical test performance requirement document.</p> <p>(a) Copies of the results of optical testing undertaken by an appropriately qualified independent approved test house <u>must</u> be included in the Technical File.</p>	✓
10	Environmental test results	<p>(a) A list of relevant Environmental tests performance requirements defined in TOPAS 2130.</p> <p>(a) Copies of the results of the Environmental testing undertaken by an appropriately qualified independent approved test house <u>must</u> be included in the Technical File.</p>	✓
11	Radio Equipment Regulations test results	<p>For all products which include any transmitting and/or receiving radio equipment</p> <p>(a) A copy of the RER Declaration Of Conformity</p> <p>(b) Reference to the RER Technical Documentation for the product (by title, document number and version).</p> <p>(c) Copies of the results of radio testing, undertaken by an appropriately qualified independent approved test house <u>must</u> be included in the Technical File. The test results should be those identified in the RER Technical Documentation and should cover any specific IR2030 requirements for the type of radio used.</p> <p>(a) A copy of the Type Examination Certificate for radio equipment not covered by a Designated EN standard.</p>	N/A

12	Primary Safety Test procedure and results	For Traffic signal Control equipment only: (a) The title, document number, version and date of the Primary Safety Test schedule. (b) A copy of the test results must be included as part of the Technical File.	N/A
13	Failure Mode Analysis	For Traffic signal Control equipment only Title, document number, version and date of the product failure mode analysis requirements and results.	N/A