

TOPAS

Traffic Open Products and Specifications

TOPAS 2508C

Performance Specification for Tactile Equipment for use at Pedestrian Crossings

Revision	Date	Scope	Authorised by
C	05/02/20	Final	Board
B	23/05/18	Final	Board

© Traffic Open Products And Specifications Limited 2020.

This document is the property of Traffic Open Products And Specifications Limited and shall not be reproduced in any media in part or in full without the prior written permission of Traffic Open Products And Specifications Limited unless this copyright statement is attached.

Contains public sector information licensed under the Open Government Licence v3.0 and are reproduced and adapted by permission.

Limitation of Liability

Traffic Open Products And Specifications Limited does not accept any liability for any losses damages injury or death or other adverse consequence arising from the use or application of this document and the information therein

(This Page left intentionally blank)

TOPAS 2508C

PERFORMANCE SPECIFICATION FOR TACTILE EQUIPMENT FOR USE AT PEDESTRIAN CROSSINGS

CONTENTS

Section

- 1 Introduction
- 2 Functional Requirements
- 3 References

Appendix Z

Technical File Content

CHANGE LOG

The following outlines significant changes to this specification, from its previous issues which do not impact on currently Registered products:

- a. General clarifications and removal of detail that relates to Controller implementations, which are not strictly part of the specification for the tactile unit. (In Issue B).
- b. Section 2.11 removed (reference to the ability of the tactile unit to be dismantled only by the use of special tools). (In Issue B).
- c. Removal of the informative guide (Appendix A) and inclusion of its basic material (labelling) have been included into the main document as a clear requirement. (In Issue B).

The following outlines significant changes to this specification, from its previous issue which may impact on currently Registered products:

- a. The direction of rotation of the tactile cone has been clarified (new section 2.9) and an overview of the tactile

performance is now given, referenced from new section 2.10 (in issue C)

- b. Detailed operate and not-operate voltages have been added to the specification – section 2.21. (In Issue B).
- c. The detailed operational voltages for the Product (section 2.20) have been removed from this specification and replaced with a reference to TOPAS 2523 where they are fully defined. (In issue C).
- d. The requirement for LV Tactile Products to include a gating signal input has been added (section 2.23) (In Issue C).
- e. Specific requirements for product labelling – section 2.32. (In Issue B).
- f. Specific requirements to comply with TOPAS 2130 for environmental performance – section 2.29. (In Issue B).
- g. Specific requirements to comply with EN50293 for EMC – section 2.30. (In Issue B).
- h. Changes in reliability requirements – section 2.31. (In Issue B).

The requirements for re-registration of existing products are defined in section 1.7.

1. INTRODUCTION

1.1 This specification covers the requirements for Tactile Equipment for use at permanent, temporary and portable signalised crossings on public highways where permitted.

1.2 TOPAS specifications are explicitly purchasing specifications and compliance with them is not mandatory. However Local and other Purchasing Authorities may typically require that equipment purchased complies with TOPAS specifications and is TOPAS registered.

1.3 Manufacturers may register products as being compliant with this specification, using the process defined in TOPAS 0600.

1.4 TOPAS registration requires manufacturers submit a Technical File to an appropriate Technical Assessor to aid compliance verification. The content requirement for the Technical File is defined in Appendix Z of this specification.

1.5 Within this specification, "The Product" shall mean all components necessary to provide a complete operational unit meeting the requirements of this specification and the common requirements defined in TOPAS 0600.

Implementation

1.6 This specification will be immediately implemented from the date of issue for all new TOPAS registrations.

1.7 For Products previously Registered against TOPAS 2508A or TOPAS 2508B which are compliant with this amended specification, manufacturers are simply required to confirm in writing that the Products remain compliant. Once confirmed Product Registration information will be migrated on the TOPAS website.

1.8 Glossary of Terms

1.9 A comprehensive glossary of terms is given in Highways England document TA 84 Code of Practice for Traffic Control and Information Systems for All-Purpose Roads.

1.10 TOPAS terms are defined in TOPAS 0600 and TOPAS 0601.

1.11 Other definitions:

Pedestrian Push Button Box: Any on-street mounted equipment used to register demands from pedestrians and other users. Typically, these will be indicators which may also include Do Not Cross and Right Of Way signalisation. And more particularly identified in TSRGD Schedule 14 Sign Table Part 2 diagrams 4003; 4003.1; 4003.3; 4003.4; 4003.6; 4003.7; 4003.8.

2 FUNCTIONAL REQUIREMENTS

General

2.1 The Product provides an indication to visually impaired pedestrians, at signal controlled pedestrian crossing facilities, of the period during which they may use the crossing.

2.2 The Product shall consist of a rotating tactile cone, control unit and power supply if required and means of fitting the tactile unit to the Pedestrian Push Button Box.

2.3 All Products, independent of technology and interface type, shall meet the requirements defined in this section.

Performance

2.4 When driven, the tactile cone shall rotate symmetrically around a central vertical axis.

2.5 The tactile cone shall rotate when a supply voltage as defined in section 2.20 is present at the tactile unit terminals.

2.6 Rotation of the tactile cone shall cease when a reverse torque equal to or greater than 0.08 Nm is applied to the tactile cone.

2.7 When driven, the tactile cone shall rotate at 60 rpm $\pm 20\%$ when a reverse torque equal to or less than 0.06 Nm is applied to the tactile cone.

2.8 When the tactile cone is not being driven, the maximum torque required to rotate it in a clockwise or anticlockwise direction shall not exceed 0.04 Nm.

2.9 The direction of rotation of the tactile cone is shown in drawings (i) and (ii)

2.10 An overview of the tactile performance is shown in drawing (iii)

Construction

2.11 The manufacturer shall provide full details of how the unit is to be fitted into standard pedestrian indicator equipment such that the tactile unit will operate as required by the specification.

2.12 The tactile unit shall be constructed to allow for installation to be carried out on site.

2.13 Where the tactile cone interfaces with the external surface of the Pedestrian Push Button Box, the diameter of the cone shall be 15 mm ± 1.0 mm.

2.14 When fitted the tactile unit shall not restrict access to the Pedestrian Push Button Box.

2.15 Any fitting accessible at the outside face of the Pedestrian Push Button Box shall not by itself allow the complete or partial removal of the tactile unit (including the tactile cone).

2.16 Where the fitting is external to the Pedestrian Push Button Box, the fitting, excluding case, shall not exceed a depth of 5.0 mm measured from the external face of the box.

2.17 When fitted to the Pedestrian Push Button Box any free vertical and lateral movement of the tactile cone shall not exceed 1.0 mm.

2.18 The tactile cone shall protrude 20 mm ± 1.0 mm when measured from the external face of the Pedestrian Push Button Box or from the surface of any external fitting when fitted.

2.19 The construction options for the cone are shown in drawings (i) and (ii) and the product shall be constructed of materials that will withstand the effects of the environment in which it is intended to operate.

Electrical Requirements

2.20 The supply for the Product shall be either nominally LV or ELV and be capable of operating with one or more of the Tactile drive signal levels as defined in TOPAS 2523.

Note. The DC supplies specified may be either positive or negative with respect to Earth / 0V.

2.21 The tactile cone shall be guaranteed to be stationary at supply voltages up to 50% of the minimum operating voltages defined in 2.20 above.

2.22 Where the Product is able to be used with LV drive signals it shall be designed such that the power supply is separated from the tactile cone drive and can be located in a signal head or similar, so that only ELV voltages are present in Pedestrian Push Button Box. (230V AC equipment is not permitted within the Pedestrian Push Button Box).

2.23 The tactile LV power supply shall provide an external gating signal input, compatible with the gating signal defined in TOPAS 2523, to prevent the activation of the Tactile cone at night or to allow activation only for a reduced period, at the start of the steady pedestrian green man.

2.24 The maximum current consumption of this input shall be 25mA.

2.25 The tactile LV power supply be may be designed to supply either one or two tactile units.

2.26 Where a dual type tactile LV power supply unit is used the two outputs shall be electrically isolated from each other.

2.27 The extra low voltage tactile drive output from a tactile LV power supply shall be fused or current limited.

2.28 All wiring, termination, earthing and labelling shall be in accordance with BS 7671.

Environmental and EMC

2.29 The Product shall operate as required by this specification when tested to the environmental requirements of TOPAS 2130.

2.30 The Product shall meet the EMC requirements defined in BS EN50293.

Reliability

2.31 The tactile Product shall be designed to have an operational design life of at least 10 years under normal operating conditions.

Marking & Labelling

2.32 The product shall be fitted with a durable label in English or international symbols which identifies:

- i) The unique identifier (part number) and serial number of the product.
- ii) The electrical supply requirements of the product.
 - Operating voltage range.
 - Maximum normal operating current consumption.
 - Maximum stall current consumption.
- iii) The function of all terminations and connections on the product.
- iv) The number of tactile units it has been designed to supply (LV units only).

Drawing (i) – tactile cone design

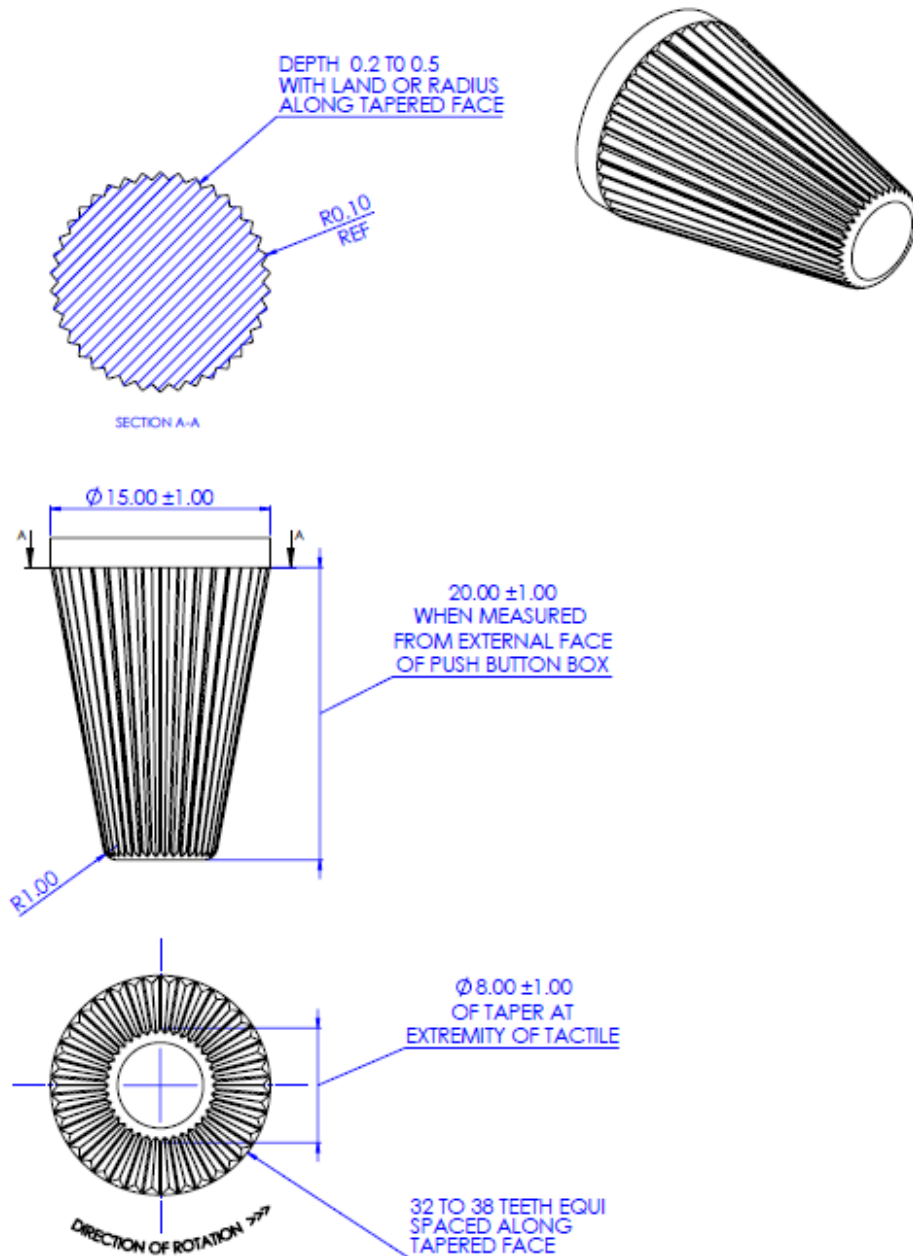

NOTES:

THE METHOD OF MOUNTING THE CONE
ON THE DRIVE SHAFT TO BE DETERMINED
BY THE MANUFACTURER

ALL CORNERS OVER THE 20mm TAPERED
SECTION MUST BE SMOOTH, EITHER BY
MOULDING OR MACHINING R0.1 OR BY
POLISHING TO APPROX R0.1

ALL DIMENSIONS IN mm

Drawing (ii) – tactile cone design

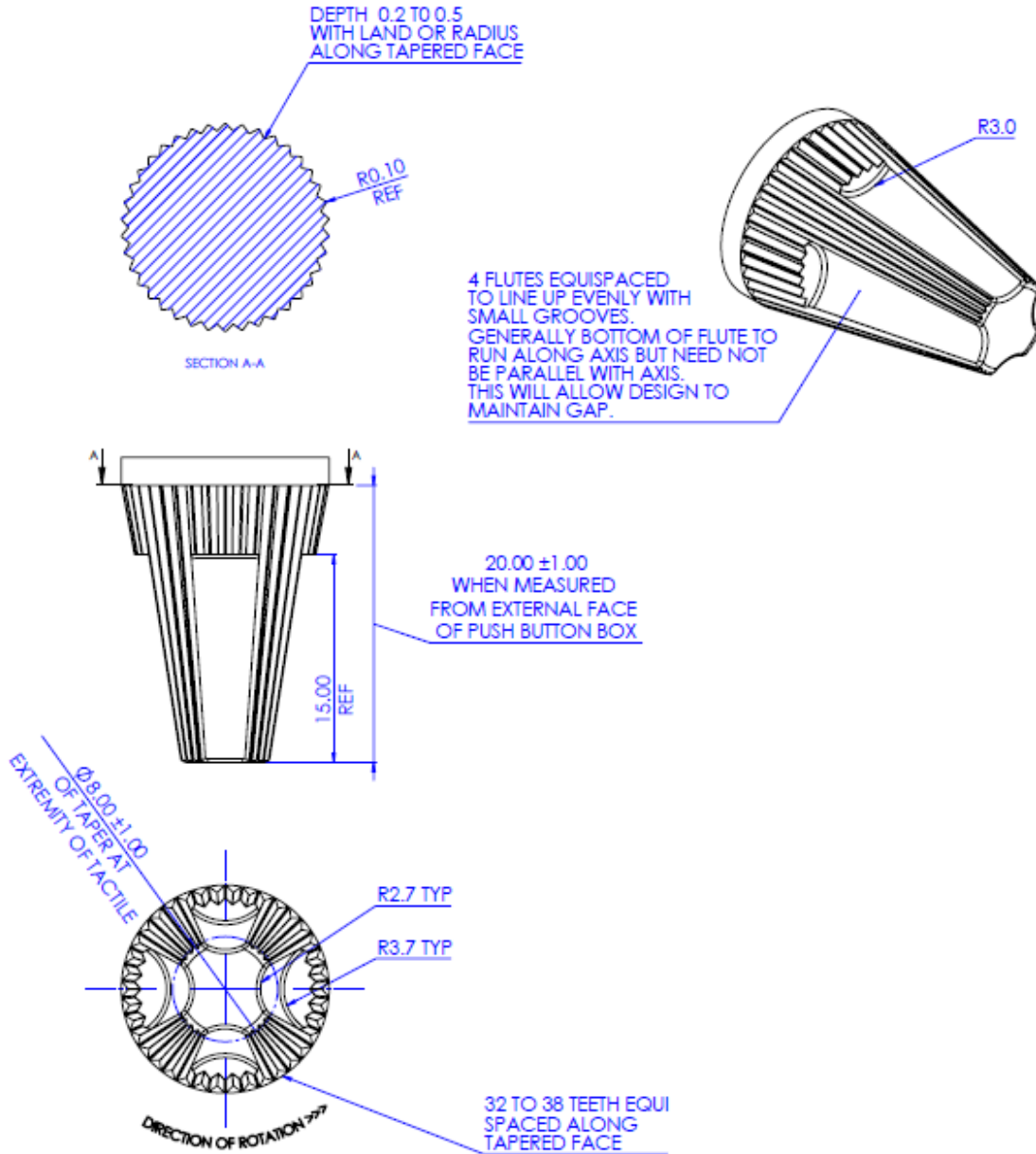

NOTES:

THE METHOD OF MOUNTING THE CONE ON THE DRIVE SHAFT TO BE DETERMINED BY THE MANUFACTURER

ALL CORNERS OVER THE 20mm TAPERED SECTION MUST BE SMOOTH. EITHER BY MOULDING OR MACHINING R0.1 OR BY POLISHING TO APPROX R0.1

ALL DIMENSIONS IN mm

Drawing (iii) – tactile performance graph

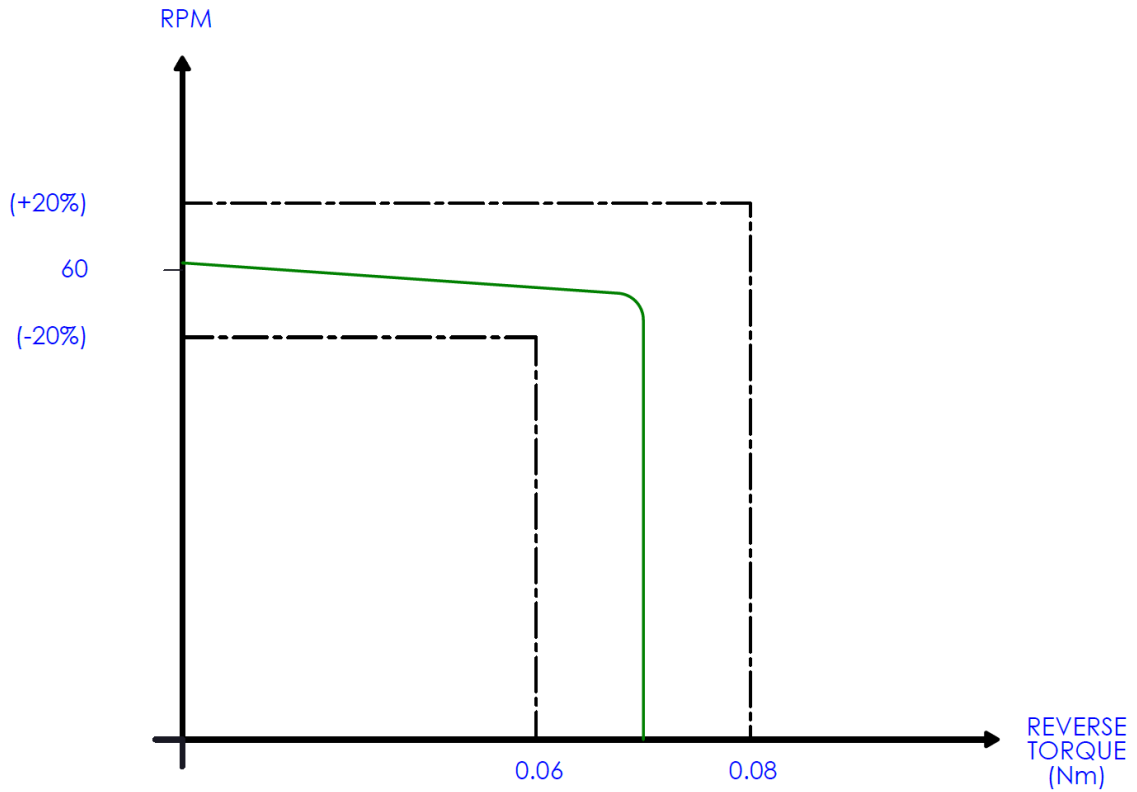

Key _____ Typical Tactile performance
 - - - - - Limit of Performance

3 REFERENCES

General

- 1 Where undated references are listed, the latest issue of the publication applies.

British Standards

- 2 The British Standards Institution, London, publishes British Standards.

BS 7671	Requirements for Electrical Installations
BS EN 50293	Electromagnetic Compatibility – Road Traffic Signal Systems Product Standard.

Specifications

- 3 TOPAS Limited specifications are available from www.topasgroup.org.uk

TOPAS 0600	TOPAS Registration process.
TOPAS 0601	TOPAS specification review process.
TOPAS 2500	Specification for Traffic Signal Controller.
TOPAS 2523	Traffic Control Equipment Interface Specification
TOPAS 2130	Environmental Tests for Road Traffic Control Equipment

Other Publications.

TSRGD	Traffic Signs Regulations and General Directions.
-------	---

APPENDIX Z TECHNICAL FILE CONTENT

This appendix defines the necessary content for a Technical File (a collection of relevant documents) which must be reviewed by an appropriate Technical Assessor as part of the TOPAS Registration process (See TOPAS 0600).

The 'ticked' items are required to be present in a Technical File used to support TOPAS Registration against TOPAS 2508C. **Please read the description criteria carefully.**

Ref	Item	Description	Required
1	Overview document	A summary document outlining the product, specifying which TOPAS and other relevant specification(s) the product has been designed to comply with, together with a detailed table of contents for the Technical File. Where external certificates or documents are referred to these shall be included either: (a) within this overview document; or (b) supplied separately as part of this Technical File.	√
2	QA accreditation certificate(s)	A copy of the Quality Management Registration Certificates for the organisation applying for TOPAS Product Registration.	√
3	Details of all required standards and regulations including CE/CA requirements that apply to the Product	A list of all standards to be complied with. Including explicit CE/CA declarations of performance/conformity for those standards, including all certificates, shall be included in this Technical File.	√
4	A functional design description of the product	Title, document number, version and date of the overall System Design Document for the Product.	√
5	Product part numbers	A list of top-level assembly part numbers and their issue states including all firmware / software part numbers and issues.	√
6	Statement of Compliance	A clause-by-clause statement of compliance against TOPAS 2508C confirming compliance or non-compliance and referencing supporting evidence.	√

		(An example template can be found on the TOPAS website)	
7	Functional test procedures and results	A list of all functional test schedules and test result documents (by document number and issue) that substantiate the Statement of Compliance.	√
8	BS EN 50293 EMC test procedures and results	(a) Title, document number, version and date of the EMC test performance requirement document. Copies of the results of EMC testing undertaken by an appropriately qualified independent approved test house <u>must</u> be included in the Technical File.	√
9	Optical test procedures and results required by this specification	For all products which have any defined optical performance requirements (a) Title, document number, version and date of the optical test performance requirement document. Copies of the results of optical testing undertaken by an appropriately qualified independent approved test house <u>must</u> be included in the Technical File.	N/A
10	Environmental test results	(a) A list of relevant Environmental tests performance requirements defined in TOPAS 2130. Copies of the results of the Environmental testing undertaken by an appropriately qualified independent approved test house <u>must</u> be included in the Technical File.	√
11	Radio Equipment Regulations test results	For all products which include any transmitting and/or receiving radio equipment (a) A copy of the RER Declaration Of Conformity (b) Reference to the RER Technical Documentation for the product (by title, document number and	N/A

		<p>version).</p> <p>(c) Copies of the results of radio testing, undertaken by an appropriately qualified independent approved test house <u>must</u> be included in the Technical File. The test results should be those identified in the RER Technical Documentation and should cover any specific IR2030 requirements for the type of radio used.</p> <p>A copy of the Type Examination Certificate for radio equipment not covered by a Designated EN standard.</p>	
12	Primary Safety Test procedure and results	<p>For Traffic signal Control equipment only:</p> <p>(a) The title, document number, version and date of the Primary Safety Test schedule.</p> <p>(b) A copy of the test results must be included as part of the Technical File.</p>	N/A
13	Failure Mode Analysis	<p>For Traffic signal Control equipment only</p> <p>Title, document number, version and date of the product failure mode analysis requirements and results.</p>	N/A