

TOPAS

Traffic Open Products and Specifications

TOPAS 2514B

Performance Specification for Light Signals for the Control of Tramcars

Revision	Date	Scope	Authorised by
B (v2)	24/03/24	Final	Board

© Traffic Open Products And Specifications Limited 2024.

This document is the property of Traffic Open Products And Specifications Limited and shall not be reproduced in any media in part or in full without the prior written permission of Traffic Open Products And Specifications Limited unless this copyright statement is attached.

Contains public sector information licensed under the Open Government Licence v3.0 and are reproduced and adapted by permission.

Limitation of Liability

Traffic Open Products And Specifications Limited does not accept any liability for any losses damages injury or death or other adverse consequence arising from the use or application of this document and the information therein

(This page is intentionally left blank.)

TOPAS 2514 B

PERFORMANCE SPECIFICATION FOR LIGHT SIGNALS FOR THE CONTROL OF TRAMCARS

CONTENTS

Section

- 1 Introduction
 - 2 Functional Requirements
 - 3 References
-
- Appendix A General Arrangement of Signal Face
 - Appendix B Informative Guide
 - Appendix Z Technical File Content

CHANGE LOG

There are significant changes in this specification compared to TOPAS 2514A.

When seeking Registration / Re-Registration Manufacturers are advised to review the whole specification and not rely solely on this change log for details.

The following outlines significant changes to this specification, from its previous issue which do not impact on currently Registered products:

- a) Update of references and bibliography
- b) Inclusion of a revised Appendix Z
- c) Inclusion of requirements for an additional indicator

The following outlines significant changes to this specification, from its previous issues which may impact on currently Registered products;

- a) None

1 INTRODUCTION

- 1.1 This specification covers the performance requirements for light signals for the control of tramcars on public highways.
- 1.2 TOPAS specifications are explicitly purchasing specifications and compliance with them is not mandatory. However Local and other Purchasing Authorities may typically require that equipment purchased complies with TOPAS specifications and is TOPAS registered.
- 1.3 Manufacturers may register products as being compliant with this specification, using the process defined in TOPAS 0600
- 1.4 TOPAS registration requires manufacturers submit a Technical File to an appropriate Technical Assessor to aid compliance verification. The content requirement for the Technical File is defined in Appendix Z of this specification.
- 1.5 Guidance to potential users of this Product is given in Appendix B.
- 1.6 Within this specification, "The Product" shall mean all components necessary to provide a complete operational unit meeting the requirements of this specification and the common requirements defined in TOPAS 0600.
- 1.7 This specification will be immediately implemented from the date of issue for all new TOPAS Registrations.
- 1.8 For Products previously Registered against TOPAS 2514A which are compliant with this amended specification, manufacturers are required to submit form TOPAS T005 using the process defined in TOPAS 0600. Once confirmed Product Registration information will be migrated on the TOPAS website.
- 1.9 This specification will be immediately implemented from the date of issue for all new TOPAS Registrations.

Glossary of Terms

- 1.10 A comprehensive glossary of terms and abbreviations may be found in the Institute of Highway Engineers guidance note "Traffic Control and Information systems".
- 1.11 TOPAS Terms are defined in TOPAS 0600 and TOPAS 0601.
- 1.12 The DfT Traffic Signs Manual, provides guidance on the application of traffic signals in the United Kingdom.

Implementation

- 1.7 This specification will be immediately implemented from the date of issue for all new TOPAS Registrations.

2 FUNCTIONAL REQUIREMENTS

General

- 2.1 The specification defines the essential requirements for light signals to control tramcars that must be declared as conformant with TSRGD Regulation 41 and to this specification before used on UK public highways.

Signal Assembly

- 2.2 The signal assembly shall be suitable for installation within an approved housing designed for a 300mm regulatory sign for mounting alongside or underneath a standard signal complying with TSRGD regulation 33.
- 2.3 The front screen(s) of the signal shall be designed such that specular reflection of light sources, external to the signal, is kept to a minimum. Any specular reflection from external sources (i.e. sun, headlamps and street lighting) shall be limited to a diameter of not greater than 25 mm.

Light Source

- 2.4 Where the light source is a separate field-maintainable component it shall:
- i) have a life expectancy of greater than 60,000 hours under normal operational conditions;
 - ii) not have a failure mode which could cause malfunction of the signal control equipment.

Construction

- 2.5 The enclosure housing the Product shall be constructed to withstand the effects of the environment in which it is intended to operate.

- 2.6 Optical components shall be designed so that when assembled they are in accurate alignment to one another, and means are to be provided to prevent displacement or misalignment of the emitters within the signal assembly.

Environmental

- 2.7 The Product shall be constructed in such a manner and from materials to meet the environmental requirements defined in TOPAS 2130.

Electrical Requirements

- 2.8 The electrical supply for The Product shall be the 'normal' and 'dimmed' signal aspect LV voltage range or ELV voltage range specified in TOPAS 2523.
- 2.9 All wiring, termination, earthing and labelling shall be in accordance with BS EN50556.

Optical Performance

Arrangement of light emitters

- 2.10 The Product shall conform in appearance to Diagram 1 or 2 of Appendix A.
- 2.11 Signals that conform to Diagram 1 shall have individual emitters to the dimensions shown.
- 2.12 Signals that conform to Diagram 2 shall have illuminated areas as shown.

Distribution of Light Output

- 2.13 The distribution of light for each emitter shall be as specified in Table 2.1 for a signal conforming to Diagram 1 of Appendix A, and Table 2.2 for a signal conforming to Diagram 2 of Appendix A.
- 2.14 When multiple light sources are used, they shall present a uniform appearance, free from excessively bright spots when viewed from any direction within that specified in Table 2.1 and Table 2.2.
- 2.15 The ratio of the maximum and minimum intensity between any 2 adjacent emitters shall not exceed 4:1 on adjacent emitters and 6:1 on non-adjacent emitters.
- 2.20 This indicator is not a signal and conveys no instruction to drivers about right of way.
- 2.21 Where such an indicator is provided it shall not be white. More particularly the colour coordinates of the on-axis light from this emitter in its normal (bright) operating state shall fall outside a circle of radius 0.2 units centred on $X = .333$, $Y = 0.333$ on the CIE 1931 XYZ Colour Space.
- 2.22 Where such an indicator is provided the luminance shall be less than the luminance of the emitters of Table 2.2 under both bright and dimmed states.
- 2.23 Where such an indicator is provided the relative luminance distribution shall correspond to that of the emitters of Table 2.2.

Dimming

- 2.16 When driven from the dimmed signal aspect voltage, the intensity I_t should be noted that the intensity of the light source shall be between $\frac{1}{4}$ and $\frac{1}{12}$ of full intensity.

Signal Chromaticity

- 2.17 The colour of light emitted from each light emitting element (Diagram 1 of Appendix A) or area (Diagram 2 of Appendix A) of the Product, for both the normal and dimmed conditions shall meet the requirements of BS 1376 Class C.
- 2.24 Where such an indicator is provided for and is located on the signal face it shall not be larger than 5mm in diameter.
- 2.25 Where such an indicator is provided it shall either be placed on the sign face but no closer than 25mm to any of the main signalling elements or as a separate facility in its own enclosure.
- 2.26 Where such an indicator is provided as a separate facility in its own enclosure this enclosure shall meet all the classes of environmental performance specified in TOPAS2130 for tram signals.

Contrast Ratio

- 2.18 The contrast ratio between an illuminated light emitting element or area and a non-illuminated light-emitting element shall be not less than 18:1.

Additional Indicator

- 2.19 The sign face may include one indicator typically for informing drivers that a demand to proceed has been received by the controller.

Horizontal \ Vertical	On Geometric Axis	3° on either side of Geometric Axis	6° on either side of Geometric Axis	12° on either side of Geometric Axis
On Geometric Axis	20	10	5	2
3° below Geometric Axis	10	7	4	2
6° below Geometric Axis	5	4	3	2

**Table 2.1 Minimum value of luminous intensity (cd) in 'bright' condition
 (refer to Diagram 1 Appendix A)**

Horizontal \ Vertical	On Geometric Axis	3° on either side of Geometric Axis	6° on either side of Geometric Axis	12° on either side of Geometric Axis
On Geometric Axis	10,000	5,000	2,500	1,000
3° below Geometric Axis	5,000	3,500	2,000	750
6° below Geometric Axis	2,500	2,000	1,500	750

**Table 2.2 Minimum value of daytime luminance (cd/m²) in bright condition
 (refer to Diagram 2 Appendix A)**

Note: Where the "Stop" legend has dual light sources, the values in Table 2.2 may be reduced by 50% for single light source operation.

3 REFERENCES

3.1 Where undated references are listed, the latest issue of the publication shall apply.

British Standards

3.2 The British Standards Institution, London, publishes British Standards.

BS 1376	Colour of Light Signals
BS 7671	Requirements for Electrical Installations
BS EN 12368	Traffic Control Equipment - Signal Heads
BS EN 50293	Electromagnetic Compatibility Road Traffic Signal Systems Product Standard
BS EN 60529	Specifications for degrees of protection by enclosures (IP Code)

Specifications

3.3 TOPAS Limited specifications are available from www.topasgroup.org.uk

TOPAS 2130	Environmental Tests for Road Traffic Control Equipment
TOPAS 2523	Traffic Control Equipment Interfacing Specification
TOPAS 0600	TOPAS Registration process

Other Publications

3.4 Other publications can be obtained from the Stationary Office:

TSR&GD	Traffic Signs Regulations and General Directions
EMC S.I.	EMC Compatibility Regulations 2016, (Statutory Instrument 2016 No 1091)

APPENDIX A GENERAL ARRANGEMENT OF SIGNAL FACE

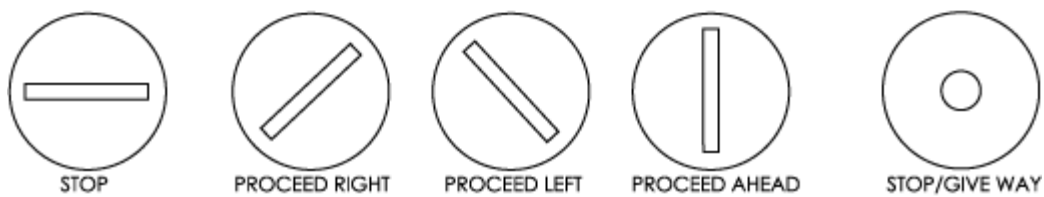
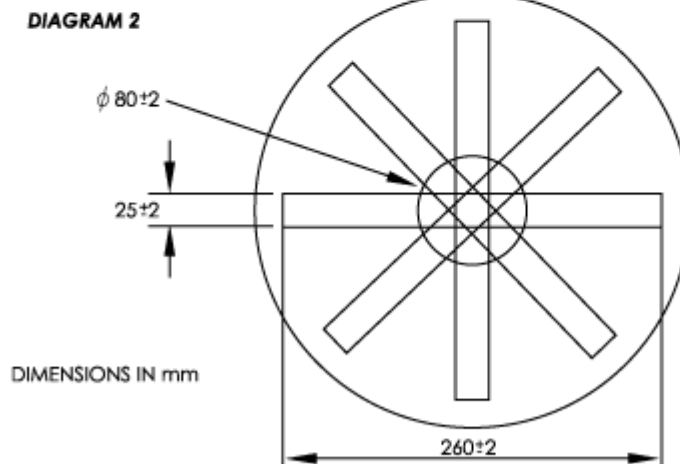
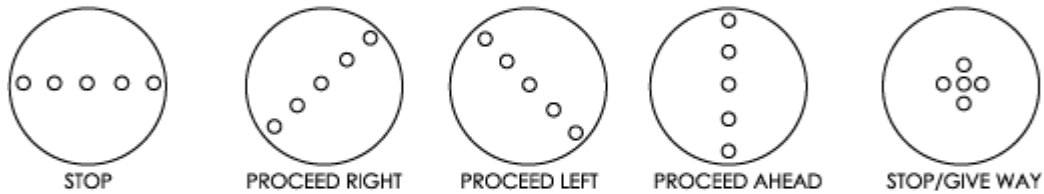
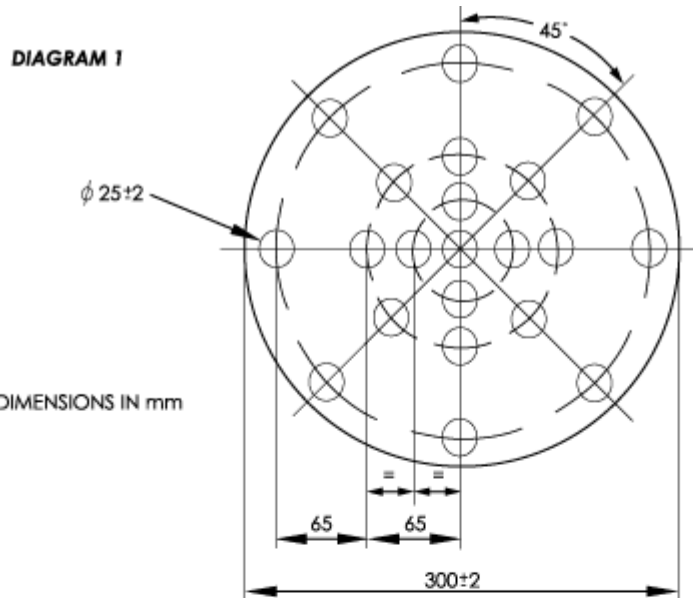

APPENDIX B INFORMATIVE GUIDE

General

- B1 This Appendix is an informative guide to Highways Authorities who wish to purchase and use “Light Signals for the control of Tram Cars”, that has been declared conformant to this specification. It is recommended that the purchasers request the Design Authority to produce copies of the certification issued by accredited test houses confirming that the Product meets the optical performance requirements of this specification.
- B2 The purchase contract should ensure that each Tramcar Light Signal head has been self certified as conformant to the TSRGD Regulation and is registered with TOPAS to this specification and is fitted with a label displaying the following:
- i) A conformity symbol identifying this TOPAS specification number;
 - ii) The unique product identifier and serial number;
 - iii) The electrical supply requirements of the product.

APPENDIX Z TECHNICAL FILE CONTENT

This appendix defines the necessary content for a Technical File (a collection of relevant documents) which must be reviewed by an appropriate Technical Assessor as part of the TOPAS Registration process (See TOPAS 0600).

Only the 'ticked' items are required to be present in a Technical File used to support TOPAS Registration against TOPAS 2514B.

Ref	Item	Description	Required
1	Overview document	<p>A summary document outlining the product, specifying which TOPAS and other relevant specification(s) the product has been designed to comply with, together with a detailed table of contents for the Technical File.</p> <p>Where external certificates or documents are referred to these shall be included either:</p> <p>(a) within this overview document; or (b) supplied separately as part of this Technical File.</p>	✓
2	QA accreditation certificate(s)	A copy of the Quality Management Registration Certificates for the organisation applying for TOPAS Product Registration.	✓
3	Details of all required standards and regulations including CE/CA requirements that apply to the Product	<p>A list of all standards to be complied with.</p> <p>Including explicit CE/CA declarations of performance/conformity for those standards, including all certificates, shall be included in this Technical File.</p>	✓
4	A functional design description of the product	Title, document number, version and date of the overall System Design Document for the Product.	✓

5	Product part numbers	A list of top-level assembly part numbers and their issue states including all firmware / software part numbers and issues.	✓
6	Statement of Compliance (An example template can be found on the TOPAS website)	A clause-by-clause statement of compliance against TOPAS 2514 confirming compliance and/or listing caveats or deviations.	✓
7	Functional test procedures and results	A list of all functional test schedules and test result documents (by document number and issue) that substantiate the Statement of Compliance.	✓
8	BS EN 50293 EMC test procedures and results	(a) Title, document number, version and date of the EMC test performance requirement document. (b) Copies of the results of EMC testing undertaken by an appropriately qualified independent approved test house <u>must</u> be included in the Technical File.	✓
9	Optical test procedures and results required by this specification	(a) Title, document number, version and date of the optical test performance requirement document. (b) Copies of the results of optical testing undertaken by an appropriately qualified independent approved test house <u>must</u> be included in the Technical File.	✓
10	Environmental test results	(a) A list of relevant Environmental tests performance requirements defined in TOPAS 2130. (b) Copies of the results of the Environmental testing undertaken by an appropriately qualified independent approved test house <u>must</u> be included in the Technical File.	✓

11	Radio Equipment Regulations test results	<p>(a) A copy of the RER Declaration Of Conformity</p> <p>(b) Reference to the RER Technical Documentation for the product (by title, document number and version).</p> <p>(c) Copies of the results of radio testing, undertaken by an appropriately qualified independent approved test house <u>must</u> be included in the Technical File. The test results should be those identified in the RER Technical Documentation and should cover any specific IR2030 requirements for the type of radio used.</p> <p>(d) A copy of the Type Examination Certificate for radio equipment not covered by a Designated EN standard.</p>	✓
12	Primary Safety Test procedure and results	<p>For Traffic Control equipment:</p> <p>(a) The title, document number, version and date of the Primary Safety Test schedule.</p> <p>(b) A copy of the test results must be included as part of the Technical File.</p>	n/a
13	Failure Mode Analysis	Title, document number, version and date of the product failure mode analysis requirements and results.	n/a