

TOPAS

Traffic Open Products and Specifications

TOPAS 2130E

Environmental Tests for Road Traffic Control Equipment

| Revision | Date | Scope | Authorised by |
|-----------------|-------------|--------------|----------------------|
| E | 29/8/24 | Final | Board |
| D | 06/06/23 | Final | Board |

© Traffic Open Products And Specifications Limited 2024

This document is the property of Traffic Open Products And Specifications Limited and shall not be reproduced in any media in part or in full without the prior written permission of Traffic Open Products And Specifications Limited unless this copyright statement is attached.

Contains public sector information licensed under the Open Government Licence v3.0 and are reproduced and adapted by permission.

Limitation of Liability

Traffic Open Products And Specifications Limited does not accept any liability for any losses damages injury or death or other adverse consequence arising from the use or application of this document and the information therein.

(This page is intentionally left blank.)

TOPAS 2130E

ENVIRONMENTAL TESTS FOR COMMUNICATIONS EQUIPMENT AND PORTABLE AND PERMANENT ROAD TRAFFIC CONTROL EQUIPMENT

CONTENTS

Section

1. Introduction
2. Mechanical tests
3. Climatic tests
4. Electromagnetic compatibility
5. Test documentation
6. References

Appendix A

Environmental test requirements for individual TOPAS specifications.

CHANGE LOG

The following outlines significant changes to this specification, from its previous issue which do not impact on currently Registered products:

Updates to reference products which have environmental testing carried out under EU Harmonised Standards, and have submitted evidence of such testing through the CE/CA marking processes under the ZA Annex of the relevant EU Standard and UK National Annex therefore. Relevant to some products under TOPAS 2516, TOPAS 2517, TOPAS 2543, TOPAS 2541

Changes to requirement for evidence of Impact Testing for HVM

The following outlines significant changes to this specification, from its previous issue which may impact on currently Registered products:

Change to the IP requirements for products under TOPAS 2540

1 INTRODUCTION

1.1 This specification defines test requirements which, together with the associated assessments methods, provide the basis for the verification of the ability of equipment to withstand the effects of specific environments likely to be encountered by road traffic monitoring and control equipment in the UK.

1.2 Testing shall be carried out by a suitably Accredited Test Facility, as defined in TOPAS 0600.

1.3 The test methods are grouped into sections relating to commonly encountered environments. In some instances tests are applicable to subcomponents or parts of a complete system.

1.4 Products Registered against specific TOPAS specifications are required to comply with the tests defined in Appendix A. (Not all tests are applicable to all products).

1.5 The definition of each test is contained in the relevant EN specification as defined by the test.

1.6 TOPAS specifications are explicitly purchasing specifications and compliance with them is not mandatory. However Local and other Purchasing Authorities may typically require that equipment purchased complies with TOPAS specifications and is TOPAS registered.

1.7 Manufacturers may Register products as being compliant with this specification, using the process defined in TOPAS 0600.

1.8 Within the applicable TOPAS product specification, "The Product" shall mean all components necessary to provide a complete operational unit or system meeting the requirements of this specification and the common requirements defined in TOPAS 0600.

Implementation

1.9 This specification takes precedence over any environmental requirements defined in individual TOPAS Technical Product Specifications.

1.10 Compliance with this specification is required, from the date of issue, for all new TOPAS Registrations.

1.11 For previously Registered Products no action is required and their Registrations will remain valid, until such times as they require re-registration, when compliance with this specification is mandatory.

1.12 For Products previously Registered against TOPAS 2130D, manufacturers are required to confirm, using the TOPAS form T005 defined in TOPAS 0600, that the Products remain compliant with this amended specification.

1.13 Manufacturers may choose to undertake tests which exceed the requirements of this specification (for example testing at a lower or higher temperature than specified). This is permitted as long as the test documentation clearly demonstrates that the Product also meets the requirements set out herein.

Presentation of Test Samples

1.14 Products submitted for testing shall be selected by the Manufacturer to represent the reasonable “worst-case” configuration for the test(s) being undertaken.

1.15 The following provides guidance to aid selection of appropriate configurations:

- a) Signal controllers shall be equipped with the maximum number of phases supported, which shall be loaded to deliver the maximum overall rated load power of the controller.
- b) For both mechanical and climatic temperature tests, cabinets and other equipment enclosures (for example above ground detector housings), shall be equipped with the maximum (worst-case) compliment of ancillary equipment. For constant high temperature tests (section 3.3), solar radiation test (section 3.4, if implemented) and damp heat tests (section 3.5), the ancillary equipment shall be operating during the test.

Note: For elevated temperature testing (section 3.3, 3.4 and 3.5) an appropriate load, simulating the worst-case power dissipation of the ancillary equipment, may be use in place of the full complement of ancillary equipment.

- c) LV and ELV signal controller variants typically have different internal construction and use (at least some) different internal assemblies. As such, where the difference may affect test results (for example, temperature and vibration testing), LV and ELV Product variants should be tested independently.

Where such difference will not affect test results (for example, water and dust penetration, mechanical protection and impact) a single test on one variant of the Product is acceptable.

- d) For Products with different cabinet / enclosure size and type variants, each individual cabinet / enclosure variant shall be treated as a separate product and be subject to the complete set of tests required for that Product.

Note: For the purpose of testing, where the colour of the cabinet will not affect the test, cabinets / enclosures of different colours need not be tested separately.

1.16 The selected Product configuration(s) shall be recorded along with the test results in the Product Technical File.

Glossary of Terms

1.17 TOPAS Terms are defined in TOPAS 0600.

1.18 Terms of specific relevance to this specification are listed below.

ASD: Acceleration Spectral Density.

EMC: Electromagnetic Compatibility.

Root-Mean-Square Value (RMS): The root-mean-square (RMS) value is the positive square root of the mean-square value. The RMS value is equal to the standard deviation if the mean value is zero.

2 MECHANICAL TESTS

Scope

2.1 This section defines a range of tests intended to verify the mechanical performance of the product.

2.2 Random Vibration (Operational)

2.2.1 This test shall be carried out in accordance with BS EN 60068-2-64 - Test Fh.

2.2.2 The test aims to simulate the mechanical hazards experienced by Equipment during operation and in its normal operational environment and modes of operation.

2.2.3 The equipment shall be tested in its normal deployed and installed state, which shall be defined by the manufacturer.

Parameters

2.2.4 Duration: 2 Hours in each of the three axes.

2.2.5 Basic motion: X, Y and Z axes.

2.2.6 Test frequency range: 5-500 Hz.

2.2.7 Acceleration Spectral Density levels.

| Vertical axis | |
|---|-------------------------------|
| Frequency (Hz) | Level (g ² /Hz) |
| 5 | 1.77E-04 |
| 8-15 | 1.31E-03 |
| 32 | 2.34E-05 |
| 197 | 1.58E-06 |
| 215 | 7.53E-06 |
| 315 | 1.73E-05 |
| 436 | 5.09E-06 |
| 464 | 8.66E-05 |
| 500 | 1.94E-05 |
| Overall RMS acceleration: 1.488E-01g | |

| Lateral and Fore/Aft axes | |
|--|-------------------------------|
| Frequency (Hz) | Level (g ² /Hz) |
| 5 | 9.50E-06 |
| 10-15 | 2.62E-04 |
| 25-48 | 1.57E-05 |
| 54-176 | 7.40E-06 |
| 205-450 | 1.22E-04 |
| 465 | 1.57E-03 |
| 500 | 8.84E-05 |
| Overall RMS acceleration: 2.48E-01g | |

2.3 Impact

2.3.1 This test shall be carried out in accordance with BS EN 62262.

2.3.2 The test is typically to verify the ability of external equipment cabinets, enclosures, boxes and housings, including display faces, to withstand mechanical impact.

2.3.3 Where equipment comprises both physical enclosures and also display faces (for example signalling equipment), both the enclosure and the display face shall be separately tested.

Parameters

2.3.4 Class IK07. (0.5 kg ball of 50mm diameter, 400mm drop height – single drop.

2.3.5 For external equipment cabinets, enclosures, boxes and housings there shall be no damage to the equipment contained within the enclosure and the equipment shall operate to its specification after the test. There shall be no degradation of the IP rating of the equipment.

2.3.6 For display faces, surface cracks are allowed provided complete penetration does not occur. There shall be no degradation of the IP rating of the equipment.

2.4 Shock

2.4.1 This test shall be carried out in accordance with BS EN 60068-2-27 Test Ea.

2.4.2 The test is intended to simulate shocks experienced by equipment during transportation. Equipment shall be tested unpackaged and for portable / temporary traffic signals, with detectors fitted.

Parameters

2.4.3 Pulse shape: Half-sine.

2.4.4 Shape Tolerances: As per test standard.

2.4.5 Velocity change tolerances: As per test standard.

2.4.6 Cross axis motion: As per test standard.

2.4.7 Method of mounting: The equipment shall be fixed as rigidly as possible to the Shock Table by appropriate means.

2.4.8 Severity: 100m/s² peak, Acceleration: 16ms, Duration: 1000 shocks in what is considered to be the most vulnerable direction, as agreed with the Test Facility. Shocks to be split equally between the negative and positive directions.

2.4.9 Initial measurements: Visual inspection and functional test to specification.

2.4.10 Testing: Equipment shall not be operating.

2.4.11 Recovery: Not applicable.

2.4.12 Final Measurements: Visual inspection and function test to specification on completion of test. Equipment to be fully functional after test. Superficial damage is permissible.

2.5 Drop and Topple

2.5.1 This test shall be carried out in accordance with BS EN 60068-2-31 Drop and Topple.

2.5.2 The test is intended to simulate miss-handling of the equipment on site. It shall be applied to all equipment as delivered on site – unpackaged, and for and for portable / temporary traffic signals, with detectors fitted.

Parameters

2.5.3 Initial Measurements: Visual inspection and function to specification.

2.5.4 Fitting of cables, covers etc. As handled at site. Covers fitted, cables not fitted.

2.5.5 Operating mode: Non-operating.

2.5.6 Edges to be used in the test where there are more than four bottom edges: Bottom edges only. All edges for which the test is practical. If more than four, select the worst case four, as agreed with the Test Facility.

2.5.7 Height of drop on to a face: 50mm.

2.5.8 Height of drop on to a corner: 50mm.

2.5.9 Final Measurements: Visual inspection and function test to specification on completion of test. Equipment to be fully functional after test. Superficial damage is permissible.

3 CLIMATIC TESTS

Scope

3.1 This section defines a range of tests to verify the performance of the product, under a variety of climatic conditions.

3.2 Constant Low Temperature (Cold)

3.2.1 This test shall be carried out in accordance with BS EN 60068-2-1 - Test Ab.

Parameters

3.2.2 Temperature: -15°C for 16 hours.

3.2.3 Equipment to be switched off during the first 15 hours of test duration. Equipment to be switched on at the beginning of the 16th hour and tested to confirm proper start-up and subsequent proper operation throughout the final hour at the low temperature, while warming up and at ambient temperature

3.3 Constant High Temperature (Heat)

3.3.1 This test shall be carried out in accordance with BS EN 60068- 2-2 - Test Bd.

Parameters

3.3.2 Temperature: 60°C for 16 hours.

3.3.3 Equipment to be switched on, fully loaded and properly operational during the test.

3.4 Solar Radiation

3.4.1 For some products this test may be used as an alternative to the Constant High Temperature test (section 3.3). (See Notes in Appendix A).

3.4.2 If performed it shall be carried out in accordance with BS EN IEC 60068-2-5 - Test S.

Parameters

3.4.3 Radiation source: As defined in Table 1 of BS EN IEC 60068-2-5.

3.4.4 Test Procedure: Sa 2 – 24 h cycle, 20 hours irradiation and 4 hours darkness.

3.4.5 Duration of Test: 24 hours

3.4.6 Temperature during Test: T1 = +25 °C, T2 = +40 °C.

3.4.7 Humidity during Test: The average relative humidity (RH) shall be 73% ± 5%.

3.4.8 Equipment to be switched on, fully loaded and properly operational during the test.

3.4.9 Final Measurement: Visual inspection and function test to specification on completion of test. Equipment to be fully functional after test.

3.5 Damp Heat (Cyclic)

3.5.1 This test shall be carried out in accordance with BS EN60068-2-30 - Test Db.

Parameters

3.5.2 Temperature 40° Variant 2, 2 cycles.

3.5.3 Equipment to be switched on, fully loaded and properly operational during the test.

3.6 Water Penetration

3.6.1 This test shall be carried out in accordance with BS EN 60529, Test 14.

3.6.2 The test is typically for external equipment cabinets, enclosures, boxes and housings which are directly exposed to the effects of weather.

Parameters

3.6.3 Class IPx5 (unless alternately specified in Appendix A).

3.6.4 Water ingress shall not be such that it could affect the performance of the equipment.

3.7 Dust Penetration

3.7.1 This test shall be carried out in accordance with BS EN 60529 Test 13.

3.7.2 The test is typically for external equipment cabinets, enclosures, boxes and housings which are directly exposed to the effects of weather.

Parameters

3.7.3 Class IP5x Cat 2 (unless alternately specified in Appendix A).

3.7.4 State of module during test:
Unpacked, closed and switched off.

3.8 Wind

3.8.1 The equipment when mounted on its support as for use, is required to withstand a wind force of up to 26m/s applied along four axis at 90 Degrees to each other, in the horizontal plane (as shown below), without toppling over or sustaining damage.

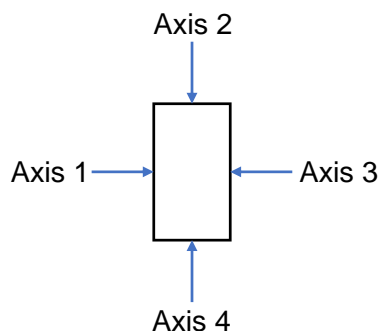

3.8.2 The ability to meet this requirement shall be demonstrated by testing (such as a wind tunnel test) or by a calculation.

3.8.3 Demonstration of compliance by calculation shall be performed by utilising BS EN 1990 and BS EN 1991-1-4 and undertaken by a Professional Engineer, qualified as CEng MICE, CEng MIStructE or equivalent.

3.8.4 The calculation shall be included in the Technical File submitted as part of the Registration process.

4 ELECTROMAGNETIC COMPATIBILITY

Scope

4.1 All electronic equipment is required to conform to the Electromagnetic Compatibility Regulations 2016 and be tested as defined in BS EN 50293 (Road traffic signal systems. Electromagnetic compatibility).

In addition, equipment shall also be compliant with any other relevant standards for electromagnetic compatibility and / or emissions, which apply to the technologies used. Specifically, where equipment includes radio transmitters or radio receivers, the requirements of the Radio Equipment Regulations (2017) and its amendments must be complied with.

4.2 There are no further requirements for EMC testing defined in this document.

5 TEST DOCUMENTATION

Test House Accreditation

5.1 All environmental testing defined in this specification shall be undertaken by a suitably accredited Test Facility as defined in TOPAS 0600.

Test Documentation

5.2 Upon completion of testing, the Test House shall prepare a formal Test Certificate to be accompanied by a supporting Test Report.

5.3 Copies of the Test Certificate(s) and Test Report(s) shall be included in the Equipment Technical File submitted as part of the TOPAS registration process.

5.4 The Test Certificate shall clearly state the details of the Equipment under test (for example by part number and serial number), the dates of testing and the basic parameters of the test. It should confirm the outcome of the tests and be signed by an appropriate signatory.

Note: Where the Environmental Test Certificate clearly includes details of the individual tests undertaken by reference to the relevant EN specification defining the test and provides a clear statement that each test has been passed, the test certificate alone may be submitted in lieu of a full test report.

6 REFERENCES

6.1 Where undated references are listed, the latest edition of the publication applies.

British Standards

6.2 British Standards are published by the British Standards Institution, London.

| | |
|-------------|---|
| BS EN 60068 | Environmental testing |
| BS EN 12368 | Traffic control equipment. Signal heads |
| BS EN 12966 | Road vertical signs - Variable message traffic signs |
| BS EN 50293 | Electromagnetic Compatibility - Road Traffic Signal Systems |
| BS EN 50556 | Road traffic signal systems |
| BS EN 60529 | Specifications for degrees of protection by enclosures (IP Code) |
| BS EN 60598 | Luminaires |
| BS EN 62262 | Degrees of protection provided by enclosures for electrical equipment against external mechanical impacts (IK code) |

Specifications

6.3 TOPAS Limited Specifications are available from www.topasgroup.org.uk

| | |
|------------|------------------------------------|
| TOPAS 0600 | TOPAS Registration process |
| TOPAS 0601 | TOPAS Specification Review process |

Other Publications

6.4 Other publications can be obtained from the Stationary Office:

| | |
|------------|---|
| TSRGD:2016 | The Traffic Signs Regulations and General Directions 2016 |
|------------|---|

APPENDIX A

ENVIRONMENTAL TEST REQUIREMENTS BY TOPAS SPECIFICATION

All tests identified with a ✓ are required to be undertaken.

Refer also to the “Specific notes to individual TOPAS specification requirements”, following this table.

| TOPAS specification | | 2500 | 2505 | 2506 | 2507 | 2508 | 2509 | 2510 | 2511 | 2512 | 2513 | 2514 | 2515 | 2516 | 2517 | 2520 | 2522 | 2540 | 2541 | 2542 | 2543 | 2544 | 2546 | 2581 | | | | | |
|--|-----|------|------|------|------|------|----------------|----------------|------|----------------|----------------|------|----------------|------------|------------|----------------|----------------|----------------|------------|----------------|------------|----------------|------------|------|---|--|---|---|---|
| Test & Specification Clause | | | | | | | | | | | | | | | | | | | | | | | | | | | | | |
| Random Vibration (Operational) BS EN 60068-2-64 - Test Fh | 2.2 | ✓ | ✓ | ✓ | ✓ | ✓ | ✓ ^d | ✓ | ✓ | ✓ | ✓ ^f | ✓ | ✓ ^g | See note j | See note j | ✓ | ✓ ⁱ | ✓ ^b | See note m | ✓ | See note p | ✓ | See note o | ✓ | | | | | |
| Impact BS EN 62262 | 2.3 | ✓ | ✓ | ✓ | ✓ | | ✓ ^d | ✓ ^q | ✓ | ✓ ^e | ✓ ^f | ✓ | ✓ | | | ✓ ^e | | ✓ ^b | | | | ✓ ^k | | | ✓ | | ✓ | ✓ | |
| Shock BS EN 60068-2-27 Test Ea. | 2.4 | | | | | | | | | | | | | | | | | | | ✓ | | | | | | | | | |
| Drop and Topple BS EN 60068-2-31 | 2.5 | | | | | | | | | | | | | | | | | | | ✓ | | | | | | | | | |
| Constant Low Temperature (Cold) BS EN 60068-2-1 - Test Ab | 3.2 | ✓ | ✓ | ✓ | ✓ | ✓ | ✓ ^d | ✓ | ✓ | ✓ | ✓ ^f | ✓ | ✓ ^g | | | | | ✓ | | ✓ ⁱ | | ✓ ^b | | | ✓ | | ✓ | | ✓ |
| Constant High Temperature (Heat) BS EN 60068- 2-2 - Test Bd. | 3.3 | ✓ | ✓ | ✓ | ✓ | ✓ | ✓ ^d | ✓ | ✓ | ✓ | ✓ ^f | ✓ | ✓ ^g | | | | | ✓ | | ✓ ⁱ | | ✓ ^b | | | ✓ | | ✓ | | ✓ |

| TOPAS Specification | | 2500 | 2505 | 2506 | 2507 | 2508 | 2509 | 2510 | 2511 | 2512 | 2513 | 2514 | 2515 | 2516 | 2517 | 2520 | 2522 | 2540 | 2541 | 2542 | 2543 | 2544 | 2546 | 2581 | | | | | |
|---|-----|----------------|----------------|----------------|----------------|----------------|-----------------|----------------|----------------|----------------|-----------------|----------------|-----------------|------------|------------|----------------|-----------------|-----------------|------------|----------------|------------|-----------------|------------|----------------|----------------|------------|---|------------|---|
| Test & Specification Clause | | | | | | | | | | | | | | | | | | | | | | | | | | | | | |
| Solar Radiation (See Note n) BS EN 60068-2-5 - Test S. | 3.4 | √ ⁿ | √ ⁿ | √ ⁿ | √ ⁿ | | √ ^{dn} | √ ⁿ | √ ⁿ | | √ ^{fn} | √ ⁿ | √ ^{gn} | See note j | See note j | √ ⁿ | √ ⁱⁿ | √ ^{bn} | See note m | | See note p | √ ⁿ | See note o | √ ⁿ | | | | | |
| Damp Heat (Cyclic) BS EN60068-2-30 - Test Db. | 3.5 | ✓ | ✓ | ✓ | ✓ | ✓ | ✓ ^d | ✓ | ✓ | ✓ | ✓ ^f | ✓ | ✓ ^g | | | ✓ | ✓ ⁱ | ✓ ^b | | ✓ ^l | | ✓ | | ✓ | ✓ | ✓ | ✓ | ✓ | |
| Water Penetration BS EN 60529, Test 14 | 3.6 | ✓ ^a | ✓ | ✓ | ✓ | ✓ ^c | ✓ ^d | ✓ | ✓ | ✓ ^e | ✓ ^f | ✓ | ✓ ^g | | | See note j | See note j | ✓ ^e | | | | ✓ ^{bh} | | See note m | ✓ ^l | See note p | ✓ | See note o | ✓ |
| Dust Penetration BS EN 60529 | 3.7 | ✓ ^a | ✓ | ✓ | ✓ | ✓ ^c | ✓ ^d | ✓ | ✓ | ✓ ^e | ✓ ^f | ✓ | ✓ ^g | | | See note j | See note j | ✓ ^e | | | | ✓ ^b | | See note m | ✓ | See note p | ✓ | See note o | ✓ |
| Wind | 3.8 | | | | | | | | | | | | | | | | | ✓ | | | | | | | | | | | |

Specific notes to individual TOPAS specification requirements

A1 This section provides additional notes and requirements for environmental testing against specific TOPAS specification requirements.

- a. Rating is for equipment in its cabinet with all doors closed. When the manual panel door is open the protection provided shall be to at least IP43.

Note: If EN 50556 is referenced for CE/CA marking purposes, a specific test result to IP54 is required, in addition to the IP55 test result required for TOPAS Registration. (Previously identified as Class V4)

- b. The tests defined shall be undertaken on any control and power supply equipment (including any communications devices and battery sets) in the complete Portable Traffic Signalling system.

Where equipment is typically mounted in the signal heads (for example wireless communication equipment), this may be tested in its normally installed location and take advantage of the protection offered by the signal head enclosure.

- c. When fitted the tactile unit shall provide a seal to IP55 between the inner and outer faces of the push button box enclosure.

The tactile unit itself shall be of corrosion resistant construction and fit for the environment in which it is used.

The tactile unit itself shall meet an IP52 rating.

- d. For audible sounders mounted inside Pedestrian Wait and Nearside indicators, the sounders may be assumed to be part of the indicator equipment and tested at the same time. (A separate test report is not required as long as the sounder is explicitly identified in the test report for the indicator equipment).

- e. Test to be performed on enclosure if the detector equipment is mounted outside of the controller cabinet.
- f. The tests defined apply to both the signal controller and the Wig-Wag Sign assembly.
- g. The tests defined shall be undertaken on any control equipment and sensors used in the complete Over Height Vehicle Detection system. If variable message signs are employed, they shall be tested as defined for TOPAS 2516.
- h. Water Penetration shall be to IPx6 when all doors are closed. When the manual panel door is open the protection provided shall be to at least IP43.
- i. Tests defined are for outstation equipment typically located inside a traffic controller cabinet which provides mechanical and environmental protection for the equipment. The tests are not intended to be applied to Instation equipment, for example a PC or Server, operating in an office environment.
- j. The environmental tests required for Variable Message Signs Registered against TOPAS 2516 and TOPAS 2517 are fully defined in BS EN 12966 and are not separately detailed in this specification.

Note 1: Where a product has been certified by a Notified/Approved Body for CE/CA marking under the BS EN 12966 ZA Annex and meets the requirements of the UK National Annex, the environmental tests do not need to be provided. For all other products that do not have CE/CA marking and compliance to the UK NA, the requirements are those stated in BS EN 12966 and the results must be evidenced in the technical file.

Note 2: the stated beam width identified in the EN 12966 is always to be regarded as minimum requirement only. All Registrations must indicate both the beam with class against which the Product is being registered, as well as any wider beam width classes that the Product meets and which have test

- evidence.
- k. For devices mounted inside Pedestrian Wait and Nearside indicators it may be assumed that these will provide mechanical protection and therefore further mechanical protection testing is not required.
 - l. Where the product installation requires access through the push button enclosure to operate it shall provide a seal at least to IP55 between the inner and outer faces of the push button box enclosure. The product itself shall be of corrosion resistant construction and fit for the environment in which it is used. The product itself shall meet an IP52 rating and be proof from the effects of condensation.
 - m. For the external detection elements of TOPAS 2541 use the tests defined for TOPAS 2505. For the sign elements and any internal detection use the tests defined in j above (for TOPAS 2516).
- NOTE Where testing of both elements – external detector and message sign as a complete product - is undertaken at the same time then an external detector may meet the environmental requirements of BS EN 12966. Where an external detector is an additional product it should meet the requirements of TOPAS 2505 as stated above.
- n. The Solar Radiation Test may be used as an alternative to the Constant High Temperature test where the equipment is likely to be directly exposed to solar radiation in its normal mode or operation. The use of this test is to be defined by the Manufacturer.
 - o. Where required, environmental tests for passively safe products are specified in the relevant (non-Topas) specifications for those products. There are no requirements for environmental tests for products Registered to TOPAS 2546 detailed in this specification.
 - p. The environmental tests required for Signal Heads Registered against TOPAS 2543 are fully defined in BS EN 12368

and are not separately detailed in this specification. Where a product has been certified by a Notified/Approved Body for CE/CA marking under the BS EN 12368 ZA Annex and meet the requirements of the UK National Annex, the environmental tests do not need to be provided.

Note 1: For all other products that do not have CE/CA marking the requirements are those stated in BS EN 12368 and the results must be evidenced in the technical file.

Note 2: This includes testing for signal head types not expressly covered in BS EN 12368 ZA Annex including 100mm roundels and regulatory signs.

- q. For bollards which are installed for the purposes of HVM evidence is required of testing to IWA 14-2:2013 or PAS 68 in addition to the other environmental testing requirements listed in this specification.